

Rod Ends Series K - Maintenance Free

Series GIXSW

Rod Ends with female thread made from heat-treated steel, zinc plated with PTFE liner, maintenance free

For use at high pressure and tension loads

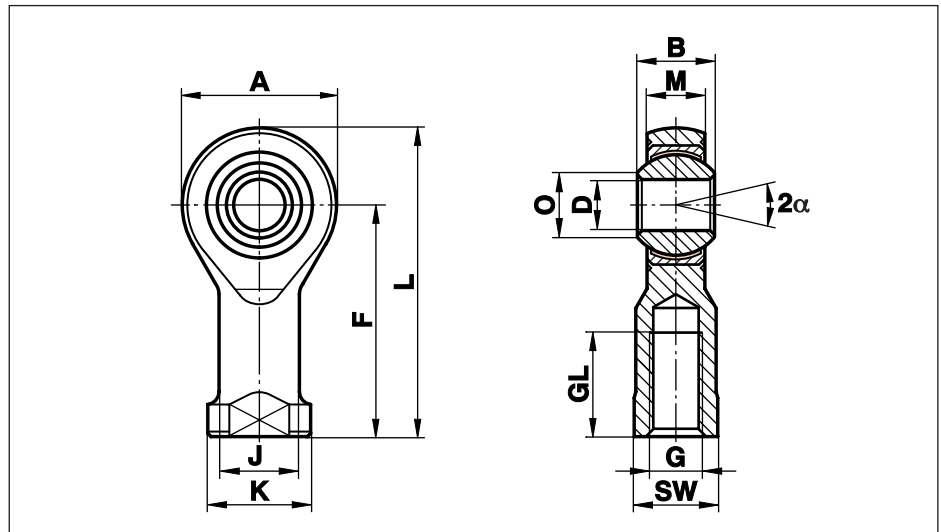

Size (D)	B	M	A	F	L	K	J	O	SW	G	GL	Static load C ₀ kN	Dynamic load C kN	Limiting speed rev/min	Weight g
6	9	6,75	20	30	40	13	10,0	8,9	11	M 6	12	16,7	9,3	530	27
8	12	9,00	24	36	48	16	12,5	10,4	13	M 8	16	25,5	16,7	420	46
10	14	10,50	28	43	57	19	15,0	12,9	17	M 10	20	34,8	23,4	350	76
12	16	12,00	32	50	66	22	17,5	15,4	19	M 12	22	42,0	32,0	300	115
14	19	13,50	36	57	75	25	20,0	16,8	22	M 14	25	57,0	42,0	260	170
16	21	15,00	42	64	85	27	22,0	19,3	22	M 16	28	67,5	52,5	230	230
18	23	16,50	46	71	94	31	25,0	21,8	27	M 18x1,5	32	81,5	64,0	210	320
20	25	18,00	50	77	102	34	27,5	24,3	32	M 20x1,5	33	93,5	78,0	190	415
22	28	20,00	54	84	111	37	30,0	25,8	32	M 22x1,5	37	114,0	97,0	170	540
25	31	22,00	60	94	124	42	33,5	29,6	36	M 24x2	42	135,0	122,0	150	750
30	37	25,00	70	110	145	51	40,0	34,8	41	M 30x2	51	184,0	168,0	130	1130
35	43	28,00	80	125	165	58	46,0	37,7	50	M 36,2	56	230,0	205,0	110	1600

only for short-term revolutions recommended

Materials:

Housing: Heat-treated steel to 42CrMo4, Aisi 4140, forged

Insert: Free-cutting steel to 9SMnPb28K, 12L13, with PTFE liner bonded to the inner surface

Ball: Bearing steel to 100Cr6, Aisi 52100, hardened, ground, polished

This series is also available sealed (see page 38) or with threaded bolt (see page 39).

Cetop connections see page 40.