

Rod Ends Series K - Heavy Duty

Series GIS

Rod Ends with female thread made from free-cutting or heat-treated steel, zinc plated and fitted with a grease nipple

Especially suited for high speed applications

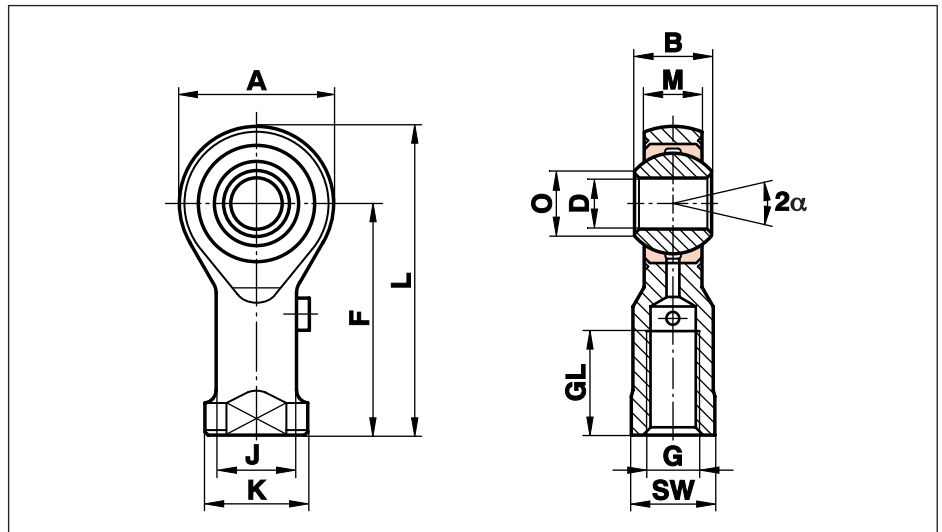

Size (D)	B	M	A	F	L	K	J	O	SW	G	GL	Static load C ₀ kN	Dynamic load C kN	Limiting speed rev/min	Weight g
2 ¹⁾	4,5	3,60	9	16	20,5	4,5	3,8	3,6	4,0	M 2	7	3,0	1,1		3
3	6,0	4,50	14	21	27,0	6,5	5,0	5,1	5,5	M 3	10	4,1	1,8		6
5	8,0	6,00	18	27	36,0	11,0	9,0	7,7	9,0	M 5	10	8,0	3,3		18
6	9,0	6,75	20	30	40,0	13,0	10,0	8,9	11,0	M 6	12	8,9	4,3	1500	27
8	12,0	9,00	24	36	48,0	16,0	12,5	10,4	13,0	M 8	16	14,1	7,1	1200	46
10	14,0	10,50	28	43	57,0	19,0	15,0	12,9	17,0	M 10	20	19,3	10,0	1000	76
12	16,0	12,00	32	50	66,0	22,0	17,5	15,4	19,0	M 12	22	23,5	13,5	860	115
14	19,0	13,50	36	57	75,0	25,0	20,0	16,8	22,0	M 14	25	21,0	17,0	750	170
16	21,0	15,00	42	64	85,0	27,0	22,0	19,3	22,0	M 16	28	32,0	21,5	660	230
18	23,0	16,50	46	71	94,0	31,0	25,0	21,8	27,0	M 18x1,5	32	38,5	26,0	600	320
20	25,0	18,00	50	77	102,0	34,0	27,5	24,3	32,0	M 20x1,5	33	44,0	31,5	540	415
22	28,0	20,00	54	84	111,0	37,0	30,0	25,8	32,0	M 22x1,5	37	53,0	38,0	500	540
25	31,0	22,00	60	94	124,0	42,0	33,5	29,6	36,0	M 24x2	42	62,0	47,0	440	750
30	37,0	25,00	70	110	145,0	51,0	40,0	34,8	41,0	M 30x2	51	82,0	64,0	370	1130
35	43,0	28,00	80	125	165,0	58,0	46,0	37,7	50,0	M 36x2	56	101,0	80,0	330	1600
40	49,0	35,00	90	142	187,0	69,0	57,0	44,2	60,0	M 42x2	60	124,0	116,0	290	2770
50	60,0	45,00	116	160	218,0	78,0	65,0	55,9	65,0	M 48x2	65	308,0	185,0	230	5000

Materials:

Housing: up to size 12 turned from free-cutting steel to 9SMnPb28K, 12L13, from size 14 forged from heat-treated steel to C22, M1023, Size 50 turned from heat-treated steel to C45, Aisi 1045

Insert: Special high strength bronze to CuSn8

Ball: Bearing steel to 100Cr6, Aisi 52100, hardened, ground, polished

This series is also available sealed (see page 38) or with threaded bolt (see page 39).

Cetop connections see page 40.

¹⁾ without lubrication fitting